

**FOTOTRAINER**  
**TECHNOLOGY**

**ray  
tec**  
VISION  
*Innovation in Sorting Equipment*

**RAYNBOW**

Software GUI  
**UNYCO**

**VISIRAT<sup>2</sup>**  
INSIDE



**STD** SENSOR SORTER  
WITH ELECTRO-PNEUMATIC EJECTION

**High Speed** DOUBLE  
PRODUCTION, SAME HIGH QUALITY



# RAYNBOW STD

# RAYNBOW High Speed



## Selection until 4 levels

RAYNBOW is a high resolution sensor sorter. It is equipped with Visible Color and NIR technology (Near Infra Red). The system can detect the presence of organic or inorganic foreign bodies (including completely black), rotten products and color defects. Ethernet connection for remote access is available. Product traceability: the installed software allows data collection during process for offline analysis and/or traceability. The software works with four control levels which can be independently parameterized and it has a simple interface. Minimal re-calibrations of the machine are required, typically only twice per year.

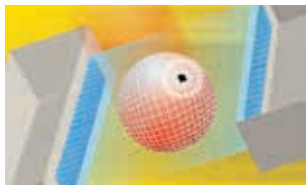

## Bilateral sensor vision

RAYNBOW is able to view the product from both sides. Banks of sensors above and below the product provide a comprehensive set of images for the vision system. The high quantity and position of sensors used allows a 4x4 mm pixel size.

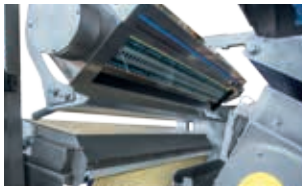

## Hexa-Chromatic lighting

RAYNBOW adopts the solid state lighting technology (L.E.D.) with 5 monochromatic wavelengths reflections + 1 monochromatic wavelength transmission. The use of light sources in the visible spectrum and in the infrared (NIR) spectrum allows for product sorting by color and by parameters which are independent from the color.



## Ejection system

RAYNBOW can be equipped with electro-pneumatic or air jet ejection system depending on the processed product.

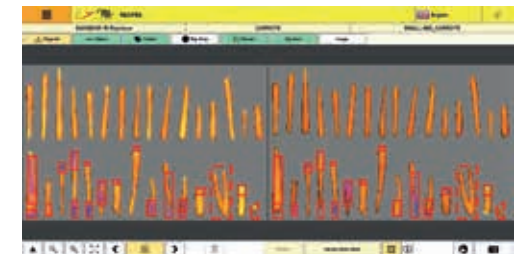
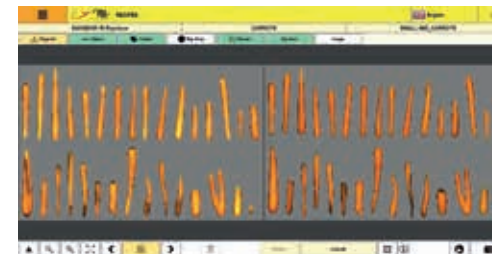

Raytec, with the introduction of the new Raynbow High Speed offers a photodiode array sensor sorter with 60% higher capacity than standard Raynbow.

Raytec have always been committed to finding the best solution with the minimum investment for customers. The market needs to limit costs without reducing quality and it is in this spirit that we have designed our **High Speed** sorter, based on the famous **Raynbow**.

The electronics of this unit are adapted to the **sorting speed**. This ranges from Raytec's standard 70 m/min (230 fpm) to 120m/min (394 fpm). Raynbow High Speed is available in the 50 channel version (50" belt width).

# FOTOTRAINER TECHNOLOGY

The Fototrainer technology has a combination of 4 analyses that combined together make the system very efficient on contaminant detection.



## LIGHTING SYSTEM

The system can be equipped with 3 different light combination:

	RG-IR	RGB-IR	CHLORO
Red	✓	✓	
Green	✓	✓	✓
Blue		✓	✓
Near Infrared 1	✓	✓	✓
Near Infrared 2	✓	✓	✓
Near Infrared 3	✓		✓
Chlorophyll			
Infrared Backlight	✓	✓	

The frequencies of the visible spectrum allows color analysis. The frequencies of the infrared spectrum allows foreign bodies and rotten products detection, even when these have the same color as the good product. The Chlorophyll analysis allows foreign body detection in green products like green beans or rot in whole apples.

## Blob

A BLOB is a group of pixels in contact with each other that are identified as defective by the sorting recipe. This allows the system to associate a "weight" to all the different kinds of defects that the sorting recipe can discriminate. Weight is associated with all the pixels that are identified as defective on the grabbed image. The system rejects a BLOB only if the BLOB weight (sum of the weights of all the adjacent defective pixels) is higher than a set value.

## Snap

The thresholds are adjustable directly from the control panel with the Snap system.

Directly on the photo grabbed by the system it is possible to verify how the system will act on the defects and which way of rejection the defects will be assigned.

## 3WAY

The system allows to have two different classes of rejection.



RAYNBOW STD  
RAYNBOW High Speed

3WAY  
OPTION

## DOUBLE REJECT IN A SINGLE SORTER

The first sorter with 4x4mm resolution celebrates its 10th birthday, just like the company that created it!

Over 130 installations of this model of machine have been made in these years.

In 2009 the double reject sorter with pneumatic finger system was presented for applications such as potatoes, peaches, tomatoes and onions.

Access to new market sectors called for further evolution which Raytec immediately responded to with the addition of air jet ejection. Today we have three different versions of 3-way machines for 4 models (20,30,40 and 50 channels), all equipped with the new Fototrainer technology.

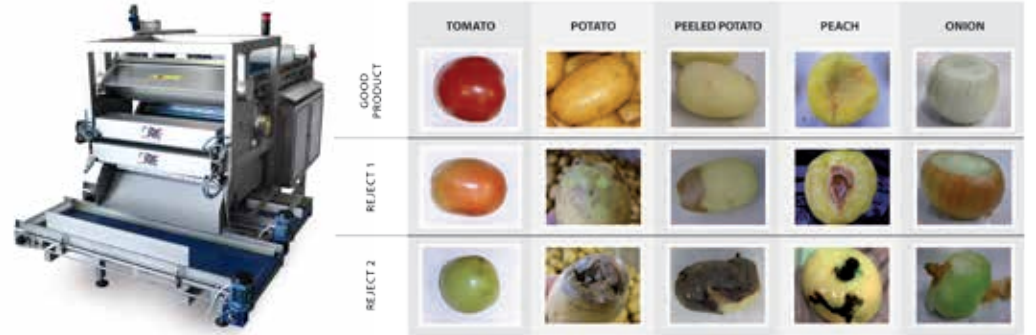

## MECHANICAL AND AIR REJECT UNIT

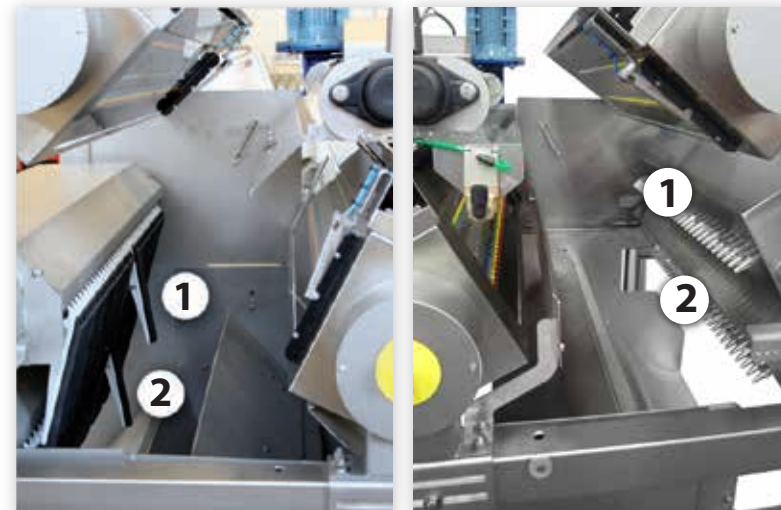

### 3WAY

THE SYSTEM ALLOWS FOR TWO DIFFERENT CLASSES OF REJECTION:

1 = good products;  
2 = foreign bodies;  
3 = color defects.

1 = good products;  
2 = big defects;  
3 = small defects.

1 = good products;  
2 = rotten products;  
3 = fruit stones.

ver.10/2016

# RAYNBOW STD

# RAYNBOW High Speed

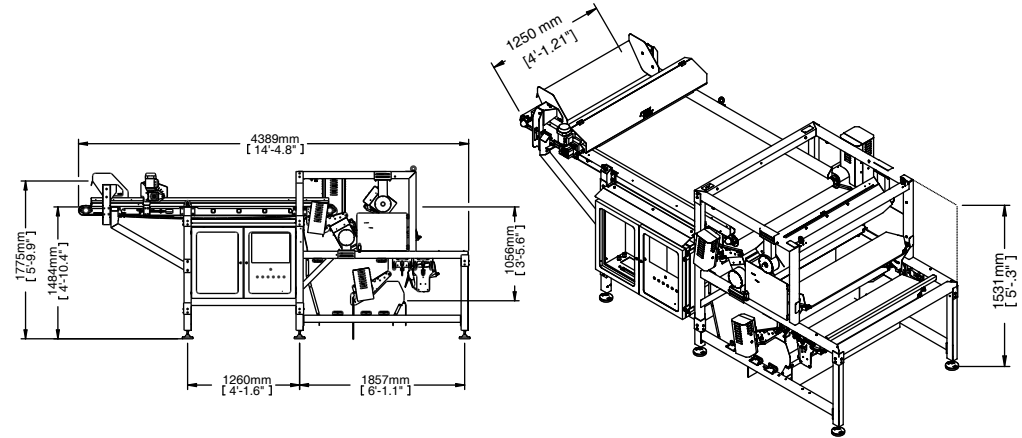
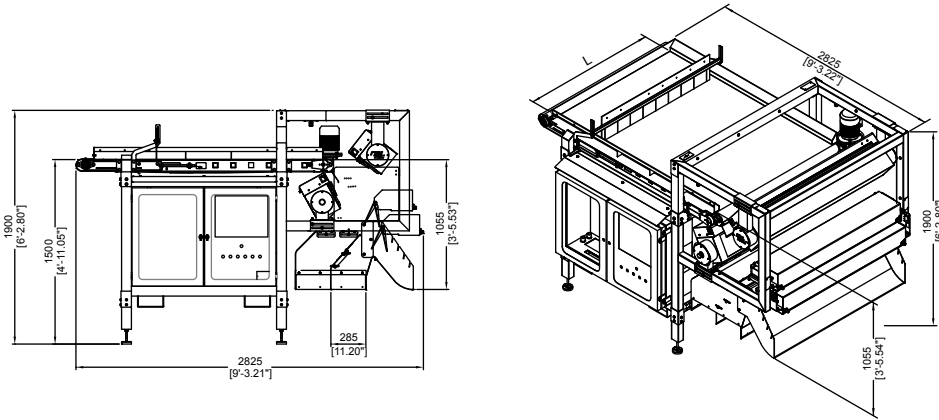

## TECHNICAL FEATURES

	20	30	40	50
Sorting channels	20	30	40	50
Vision area width (L)	500mm (20")	750mm (30")	1000mm (40")	1250mm (50")
Pixel Dimension	4x4mm (0.16"x0.16")			
Control and diagnostic device	Interactive LCD Touch-Screen color digital panel onboard			
Rejection channel width	25mm (1")			
Rejection type	Driven by fingers (Mod. M) / Air jets (Mod. J)			
External and/or remote connection	Ethernet and/or modem			
Vision glass cleaning device	Integrated and pneumatically controlled			
Conveyor speed	50÷75 m/min [164÷246 ft/min]			
<b>Power supply and consumption</b>				
Power supply	3-Ph + Gnd			
Voltage	400/480 V			
Frequency	50/60 Hz			
Installed power	1.3/1.5 kW			
Applied air treatment (pneumatic circuit)	Dehumidification – Filtration – Lubrication			
Lubricating system (pneumatic circuit)	Food grade and pharmaceutical compatible			
Working pressure (pneumatic circuit)	6÷8 bar [87÷116 psi]			
Typical consumption (pneumatic circuit)	120 NI/min [4.2 cft/min] (Mod. M)* /1200 NI/min [42 cft/min] (Mod. J)*			
Max. air flow rate (pneumatic circuit)	1000 NI/min [35 cft/min] (Mod. M) /3600 NI/min [127 cft/min] (Mod. J)			
Water treatment (water circuit)	Filtration			
Working pressure (water circuit)	1÷4 bar [14÷58 psi]			
Water consumption (water circuit)	Lower than 0.1 m3/h [26.4 US gal/h]			

## TECHNICAL FEATURES

Sorting channels	50
Vision area width (L)	1250mm (50")
Pixel Dimension	4x4mm (0.16"x0.16")
Control and diagnostic device	Interactive LCD Touch-Screen color digital panel onboard
Rejection channel width	25mm (1")
Rejection type	Driven by fingers (Mod. M) / Air jets (Mod. J)
External and/or remote connection	Ethernet and/or modem
Vision glass cleaning device	Integrated and pneumatically controlled
Conveyor speed	120 m/min [393 ft/min]
<b>Power supply and consumption</b>	
Power supply	3-Ph + Gnd
Voltage	400/480 V
Frequency	50/60 Hz
Installed power	1.3/1.5 kW
Applied air treatment (pneumatic circuit)	Dehumidification – Filtration – Lubrication
Lubricating system (pneumatic circuit)	Food grade and pharmaceutical compatible
Working pressure (pneumatic circuit)	6÷8 bar [87÷116 psi]
Typical consumption (pneumatic circuit)	120 NI/min [4.2 cft/min] (Mod. M)* /1200 NI/min [42 cft/min] (Mod. J)*
Max. air flow rate (pneumatic circuit)	1000 NI/min [35 cft/min] (Mod. M) /3600 NI/min [127 cft/min] (Mod. J)
Water treatment (water circuit)	Filtration
Working p ressure (water circuit)	1÷4 bar [14÷58 psi]
Water consumption (water circuit)	Lower than 0.1 m3/h [26.4 US gal/h]